

# SARGENT ME40 INTERFACE Revision 1 Part No15088

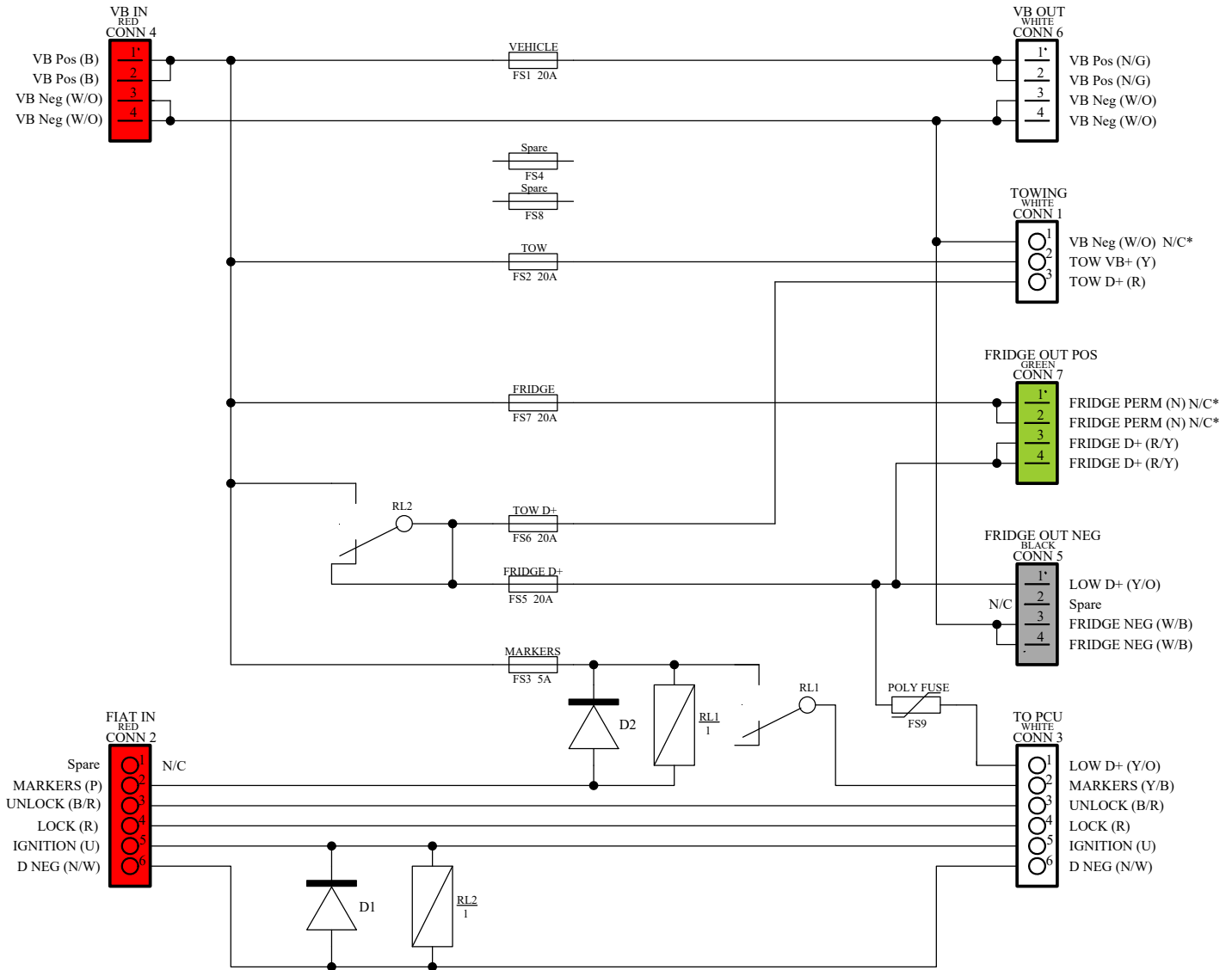

## Relays

PL1 TYCO  
V23086-C1001-A403  
++1632-42D  
PL2 TYCO  
V23076-A1001-C133  
++163110

## Wire colour ledgend (Colours show in brackets)

B BLACK	G GREEN
N BROWN	U BLUE
R RED	P PURPLE
O ORANGE	W WHITE
Y YELLOW	

N/C Not connected

N/C\* Not connected in  
Auto-trail Scout

Drawn from an EM40 to support an understanding of the EM40 function and it's control of fridge circuits.